



Pinnacle-Flo, Inc.

Pinnacle-Flo, Inc.



Blue Dog
AODD Pump





Blue Dog

AODD

Pump Series

Air Operated Double Diaphragm

Quality: Bolt together design

Low Maintenance

Smooth passage ways

Thicker casted and molded parts

Performance: Self-Priming

Flows from 05. GPM to 250 GPM

Non Lubricated Air Motor

Newly designed Diaphragms and Parts for better sealing against leaks

Capable of running dry without damage

Versatility: Place anywhere there is air

Pump thick products

Pump thin products

Pump shear sensitive products





Pinnacle-Flo, Inc.

Limited Pump Warranty

Pinnacle-Flo warrants all equipment in this document which is manufactured by Pinnacle-Flo, Inc. to be free from defects in material and workmanship on the date of sale to the original purchaser for use. With the exception of any special/extended, or limited warranty given by Pinnacle-Flo.

This warranty does not cover, and Pinnacle-Flo, Inc. will not be liable for general wear and tear, or any malfunction, damage or wear caused by faulty installation, misapplication, abrasion, corrosion, inadequate or improper maintenance, negligence, accident, tampering or substitution of parts not manufactured by Pinnacle-Flo, Inc.

This warranty is conditioned upon the prepaid return of the equipment claimed to be defective to an authorized Pinnacle-Flo, Inc. distributor for verification of the defect. If the defect is verified, Pinnacle-Flo, Inc. will repair or replace free of charge any defective parts. The pump will be returned to the original purchaser prepaid. If inspection of the pump does not show any defective material or workmanship, then the repairs will be made at a reasonable charge, which may include the cost of parts, labor and transportation.





Blue Dog Air Operated Double Diaphragm Pump

Pinnacle-Flo's Blue Dog series of AODD (Air Operated Double Diaphragm) pumps are ideal for OEM installations, general industrial and food process applications. The Blue Dog pumps can pump light to viscous product and can even be used (when grounded) in explosive areas due to the pneumatic air motor.



Why use a Blue Dog air operated double diaphragm pump?

- *Self-Priming*
- *No Electrical Wires to Run*
- *Portable*
- *Run Dry Capabilities*
- *Low Material Shear*
- *No Mechanical Seals*
- *Easy to Maintain*
- *Easy to Install*
- *Block the Pump in Without Damage to the Pump*



Pump Model and Material Code

Pump Model = **BD** 25 **AL** **PP** / **TF** / **TF** / **PP**

Brand:

BD=Blue Dog

Pump Size

06 = 1/4"
 10 = 3/8"
 15/20 = 1/2"- 3/4"
 25 = 1"
 40 = 1-1/2"
 50 = 2"
 80 = 3"
 100 = 4"

Center Block Materials:

AL = Aluminum
PP = Polypropylene
SS = Stainless Steel

Wetted Body Material:

AL = Aluminum
PP = Polypropylene
PM = POM
LL = 316 SS
ET = ETFE (Tefzel)
AC = Cast Iron
KV = Kynar

Valve Seat:

TF = Teflon
ST = Santoprene
HY = Hytrel
VT = Viton
BN = Buna-N
EP = EPDM
KV = PVDF (Kynar)
LL = 316 SS
PP = Polypropylene
ET = ETFE (Tefzel)

Valve Ball:

TF = Teflon
ST = Santoprene
HY = Hytrel
VT = Viton
BN = Buna-N
EP = EPDM
KV = PVDF
LL = 316 SS
CM = Ceramic
PP = Polypropylene

Diaphragm:

TF = Teflon
ST = Santoprene
HY = Hytrel
VT = Viton
BN = Buna-N
EP = EPDM
PU = Polyurethane



Operation Temperature Limitations

Diaphragm Material	Maximum	Minimum
Viton: Excellent corrosion resistance, resistance to various acids (including the median concentration of oxidizing acids), alkali, salt, petroleum products, hydrocarbons, etc.	350°F / 176.6°C	-40°F / -40°C
PTFE (Teflon): Excellent corrosion resistant, almost resistant to all chemical media (including concentrated nitric acid and aqua regia), Except melting of lithium, potassium, sodium, chlorine trifluoride, sulfur – speed liquid fluorine.	350°F / 176.6°C	40°F / 4.4°C
Santoprene: Good abrasion resistance, chemical resistance and heat resistance; suitable for general acid and alkali. Good substitute for EPDM/EPR materials. Not suitable for solvent.	220°F / 104.4°C	-20°F / -28°C
Hytrel: Good abrasion resistance, used in most of the neutral fluids. Good substitute for Buna-N materials.	220°F / 104.4°C	-20°F / -28°C
EPDM: Abrasion resistance, aging resistance, ozone resistance; suitable for general acid and alkali.	250°F / 121.6°C	-40°F / -40°C
Buna-N: Widely used in gasoline and other petroleum base products; suitable for use at room temperature.	212°F / 100°C	-40°F / -40°C
Pump Body Materials		
PP: Medium abrasion resistance, good chemical resistance, good versatility, especially for common acid-based products.	150°F / 65°C	40°F / 4.4°C
POM: Good solvent resistance, abrasion resistance, low friction and low moisture absorption.	150°F / 65°C	40°F / 4.4°C
PVDF: Good strong chemical resistance, crush resistance, abrasion resistance, good corrosion resistance for acid, alkali and variety of organic solvents.	200°F / 93.3°C	40°F / 4.4°C

Note: The maximum and minimum temperature is the limited operating temperatures of these materials. Temperature and pressures will affect the diaphragm life. Operating at maximum or minimum temperature, cannot achieve maximum life.

Pinnacle-Flo Inc. is a leader in the fluid handling market. We manufacture many types of pumps from centrifugal to positive displacement. It is our goal to provide the highest quality of products at a competitive price and the technical support needed, to allow our distribution network, become and stay successful.

Pinnacle- Flo manufactures the product needed to meet the market's needs. Featured in this product brochure is our Pinnacle Blue Dog Air Operated Double Diaphragm Pump. Sizes from 1/4" to 3", ball or flapper type, aluminum to 316 stainless steel. If you need it we have it.

How to correctly size the pump

It is always best to select the pump nearest to the center of the curve (know the GPM and PSI required), and determine the SCFM (Standard Cubic Feet Per Minute) required to operate the pump. The SCFM required is on each pump curve, and remember, it is always a good practice not to supply more pressure than what is needed to get the job done.

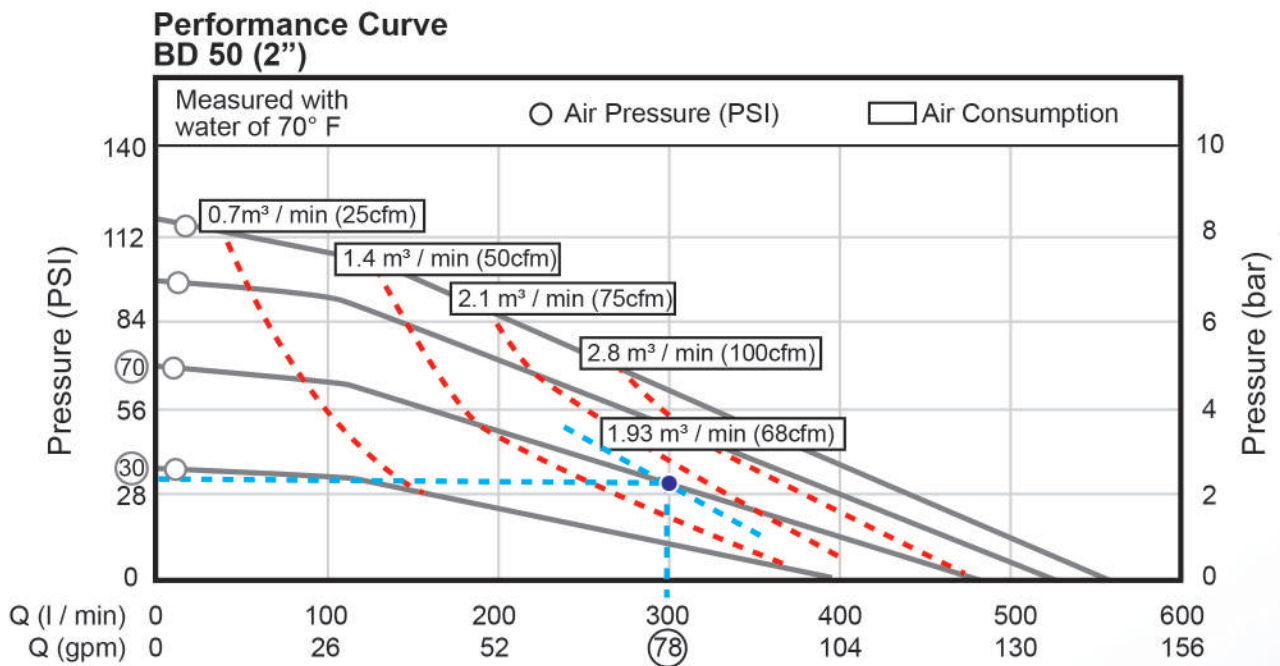

In order to determine the proper pressure and CFM required, reference the above pump curve. For an example we have selected a 2" Model BD50 pump with a design condition of 78 GPM and 30 PSI.

At the design point the pump will require 70 PSI and 68 CFM. To determine this follow the solid line back to the left to read the air pressure rating.

The CFM requirement are shown with dashed lines. This point falls between the 75 CFM and 50 CFM lines. The approximate air volume required is 68 CFM.



BD 06 Plastic Pump



Performance Curve

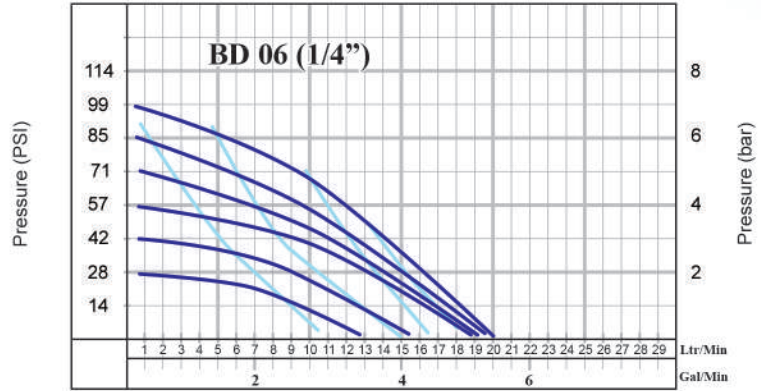

Technical Parameters	Material Specifications
Suction Lift (mwc) - Dry 2.1 - Wet 3.7 - 6.4	Diaphragm: Santoprene, Hytrel, Teflon, Viton, EPDM, Buna-N
Max particle diameter (mm) 1.6	Pump Body: PP, PVDF, POM
Suction and Discharge 3/8"	Check Valve: PP, PVDF, POM
Air inlet size 1/4"	Center Block: PP
Max flow 5.5 GPM	WEIGHT
Max Head - 230 Feet	PP Pump / POM Pump 3.3 lbs.
Max air inlet pressure 102 PSI	PVDF Pump: 4.4 lbs.

Dimensions

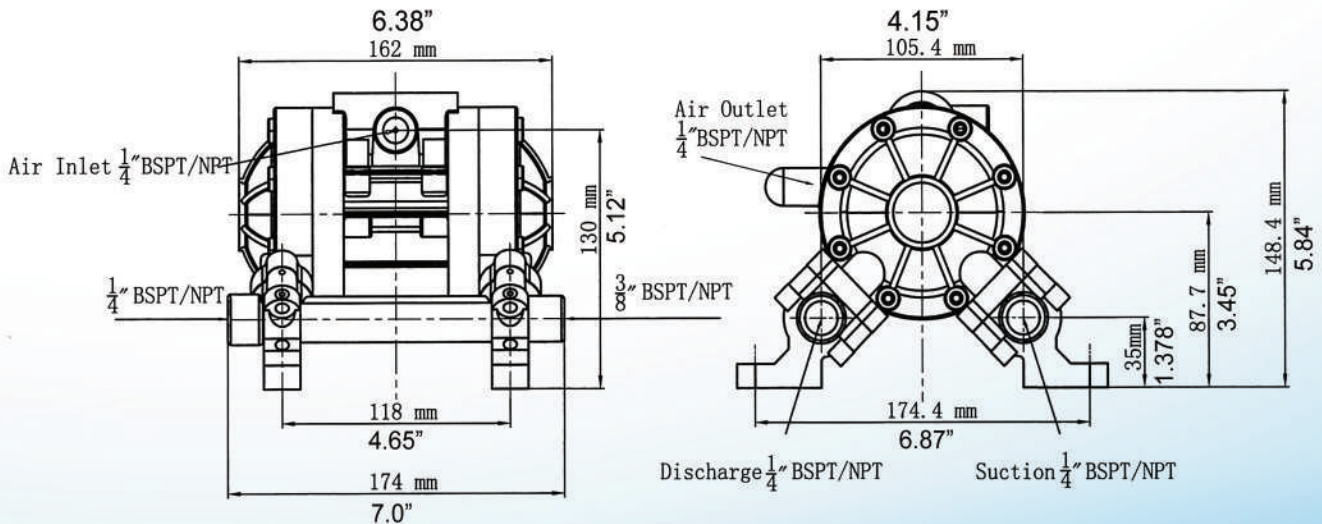



BD 10 Plastic Pump



Performance Curve

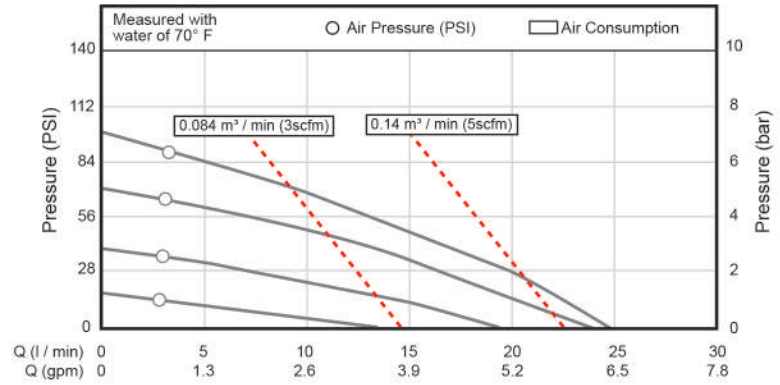

Technical Parameters	Material Specifications
Suction Lift (mwc) - Dry 2.1 - Wet 3.7 - 6.4	Diaphragm: Santoprene, Hytrel, Teflon, Viton, EPDM, Buna-N
Max particle diameter (mm) 1.6	Pump Body: PP, PVDF, POM
Suction and Discharge 3/8"	Check Valve: PP, PVDF, POM
Air inlet size 1/4"	Center Block: PP
Max flow 7 GPM	WEIGHT
Max Head - 230 Feet	PP Pump / POM Pump 3.3 lbs.
Max air inlet pressure 102 PSI	PVDF Pump: 4.4 lbs.

Dimensions

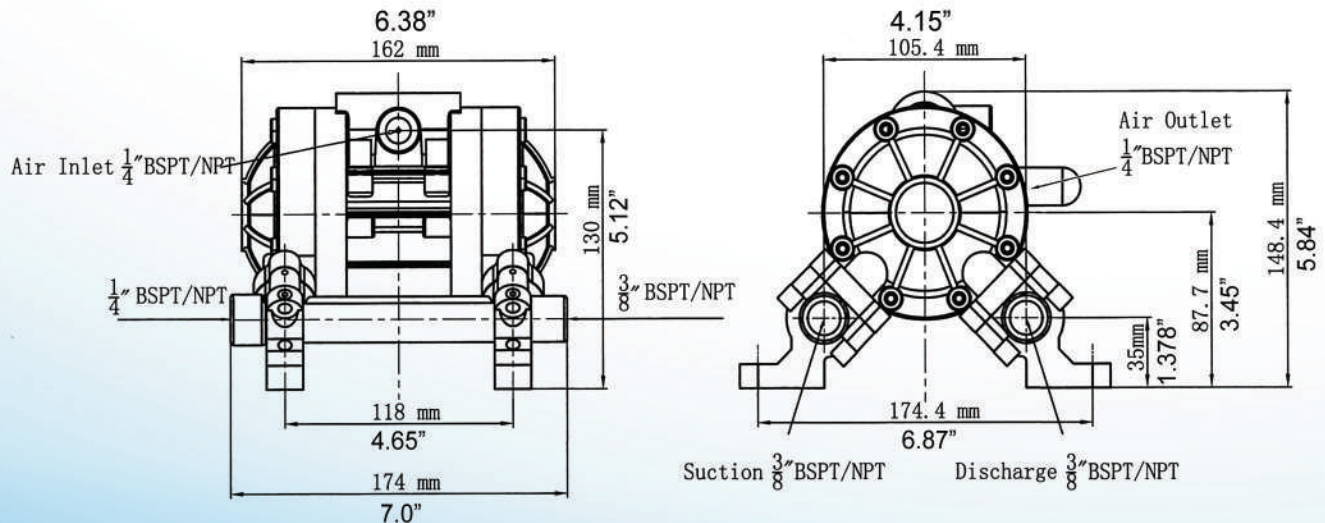



BD 15 / 20

Aluminum Pump

Stainless Steel Pump

Plastic Pump



Weight:

Aluminum: 10 lbs.
 Stainless Steel : 16.5 lbs.
 Plastic: 10 lbs.

Performance Curve

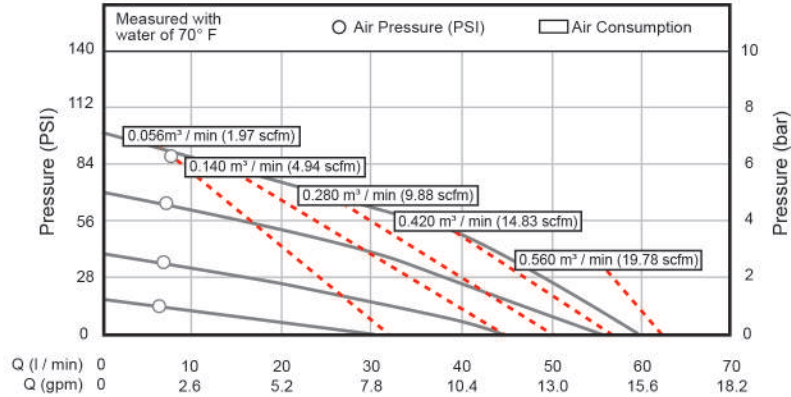

Technical Parameters

Suction Lift (mwc) - Dry 4
- Wet 7.6
Max particle diameter (mm) 2.5
Suction and Discharge 1/2" 3/4"
Air inlet size 3/8"
Max flow 15 GPM
Max Head - 275 Feet
Max air inlet pressure 102 PSI

Dimensions

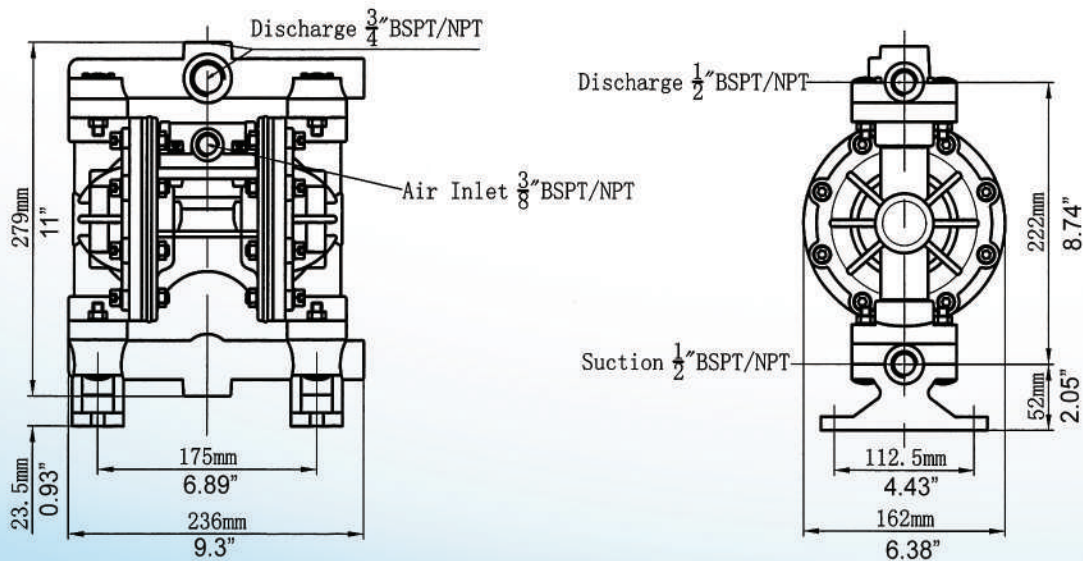



BD 25 Aluminum / Cast Iron Pump



Performance Curve

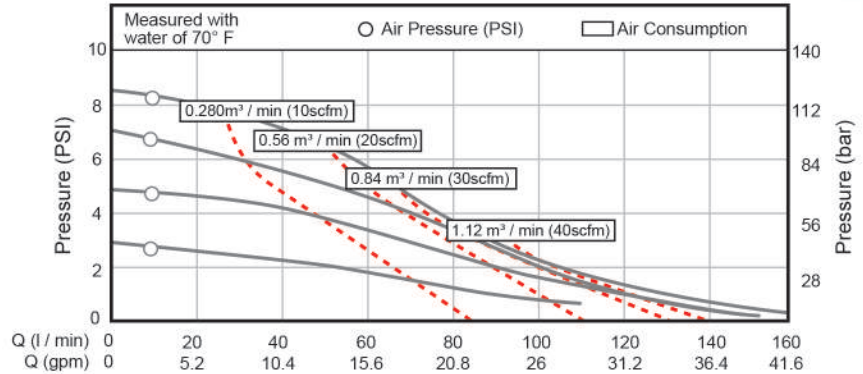

Technical Parameters	Material Specifications
Suction Lift (mwc) - Dry 4 - Wet 8	Diaphragm: Santoprene, Hytrel, Teflon, Viton, EPDM, Buna-N
Max particle diameter (mm) 4	Pump Body: AL, CI
Suction and Discharge 1"	Check Valve: ST, HY, TF, VT, SS
Air inlet size 1/2"	Center Block: PP, AL, SS
Max flow 42 GPM	WEIGHT
Max Head - 275 Feet	Aluminum Pump 24 lbs.
Max air inlet pressure 122 PSI	Cast Iron Pump: 55 lbs.

Dimensions

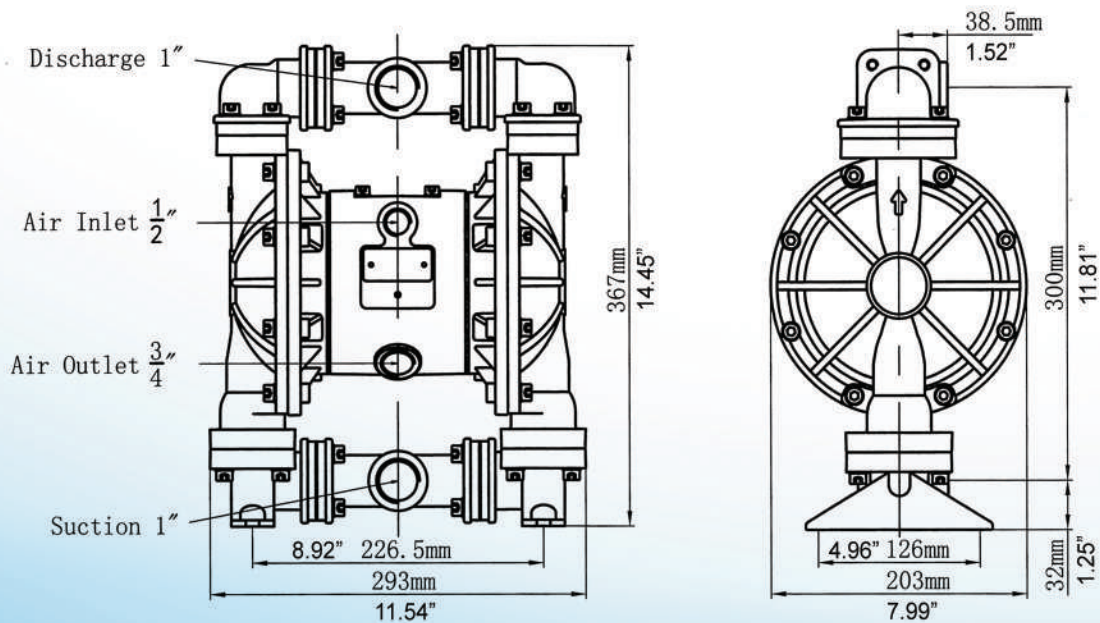



BD 25 Stainless Steel Pump



Performance Curve

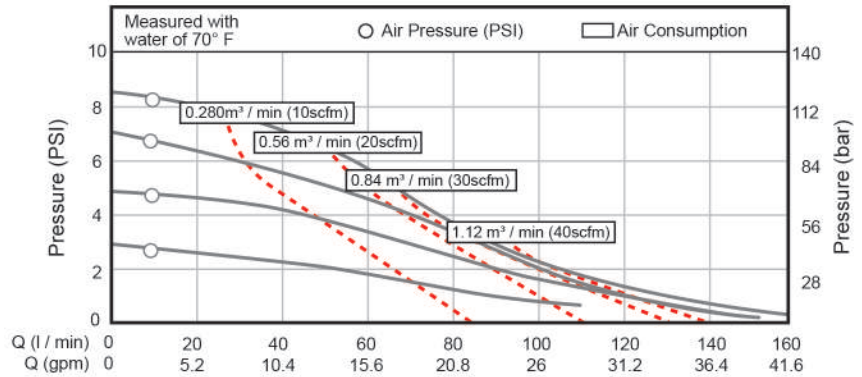

Technical Parameters	Material Specifications
Suction Lift (mwc) - Dry 4 - Wet 8	Diaphragm: Santoprene, Hytrel, Teflon, Viton, EPDM, Buna-N
Max particle diameter (mm) 4	Pump Body: SS304, SS316, SS316L
Suction and Discharge 1"	Check Valve: ST, HY, TF, VT, SS, CM
Air inlet size 1/2"	Center Block: PP, AL, SS
Max flow 42 GPM	WEIGHT
Max Head - 275 Feet	SS304 Pump 35 lbs.
Max air inlet pressure 122 PSI	SS316 Pump: 35 lbs.

Dimensions

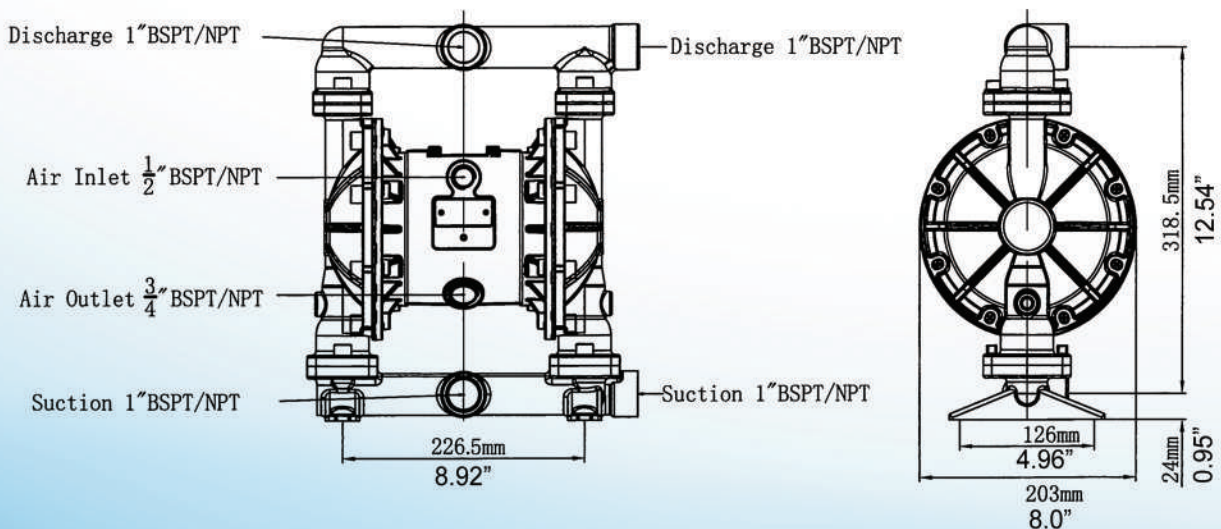



BD 25 Plastic Pump

Performance Curve

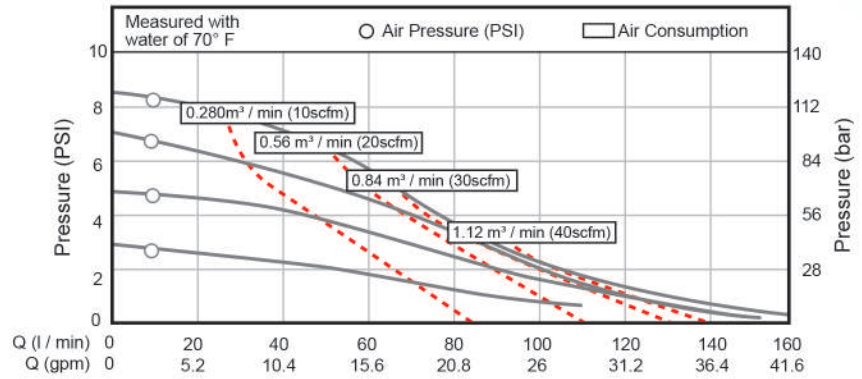
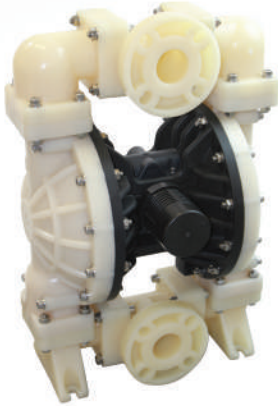

Technical Parameters	Material Specifications
Suction Lift (mwc) - Dry 4 - Wet 8	Diaphragm: Santoprene, Hytrel, Teflon, Viton, EPDM, Buna-N
Max particle diameter (mm) 4	Pump Body: PP, PVDF, POM
Suction and Discharge 1"	Check Valve: TF, SS, ST, HY, VT, CM
Air inlet size 1/2"	Center Block: PP, AL, SS
Max flow 42 GPM	WEIGHT
Max Head - 275 Feet	PP pump / POM Pump 20 lbs.
Max air inlet pressure 122 PSI	PVDF Pump: 26 lbs.

Dimensions

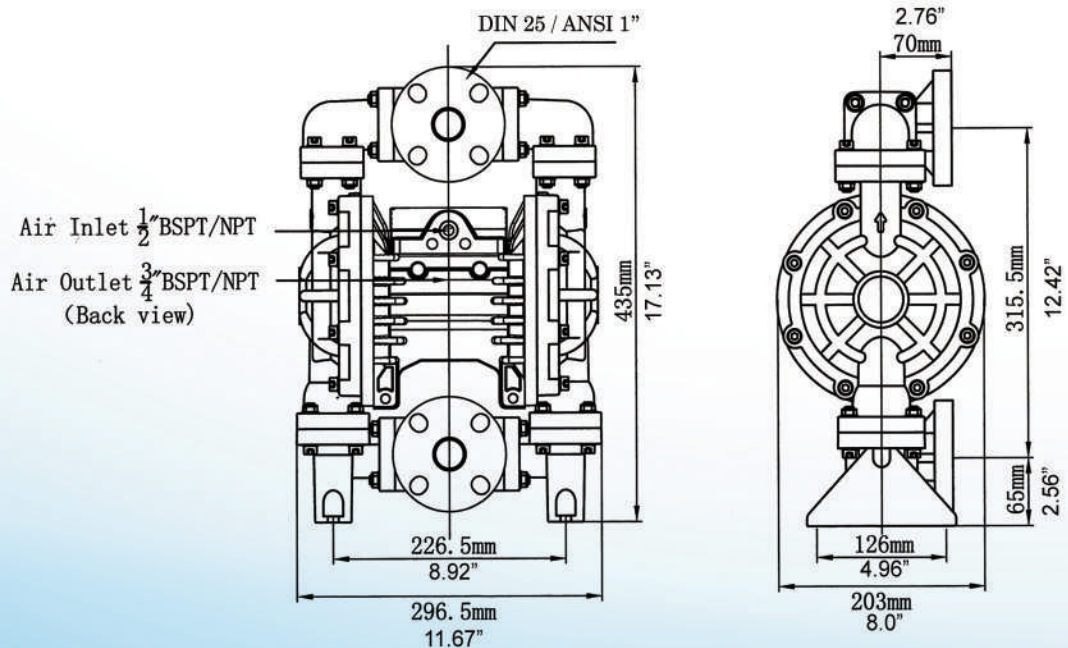



BD 40 Aluminum / Cast Iron Pump



Performance Curve

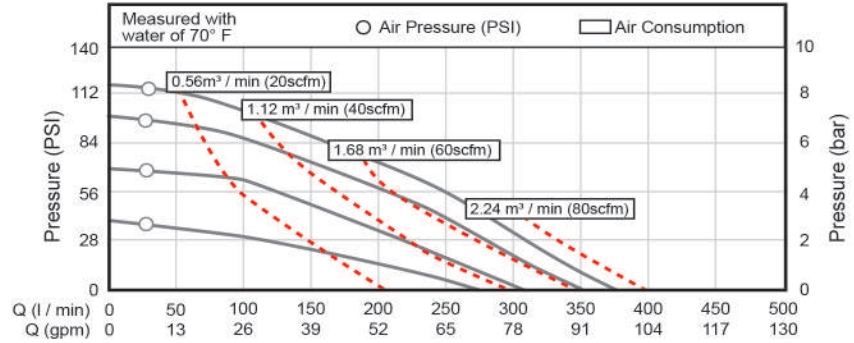

Technical Parameters	Material Specifications
Suction Lift (mwc) - Dry 5 - Wet 8	Diaphragm: Santoprene, Hytrel, Teflon, Viton, EPDM, Buna-N
Max particle diameter (mm) 5	Pump Body: AL, CI
Suction and Discharge 1-1/2"	Check Valve: ST, HY, TF, VT, SS, CM
Air inlet size 1/2"	Center Block: PP, AL, SS
Max flow 95 GPM	WEIGHT
Max Head - 276 Feet	Aluminum Pump 44 lbs.
Max air inlet pressure 102 PSI	Cast Iron Pump: 110 lbs.

Dimensions

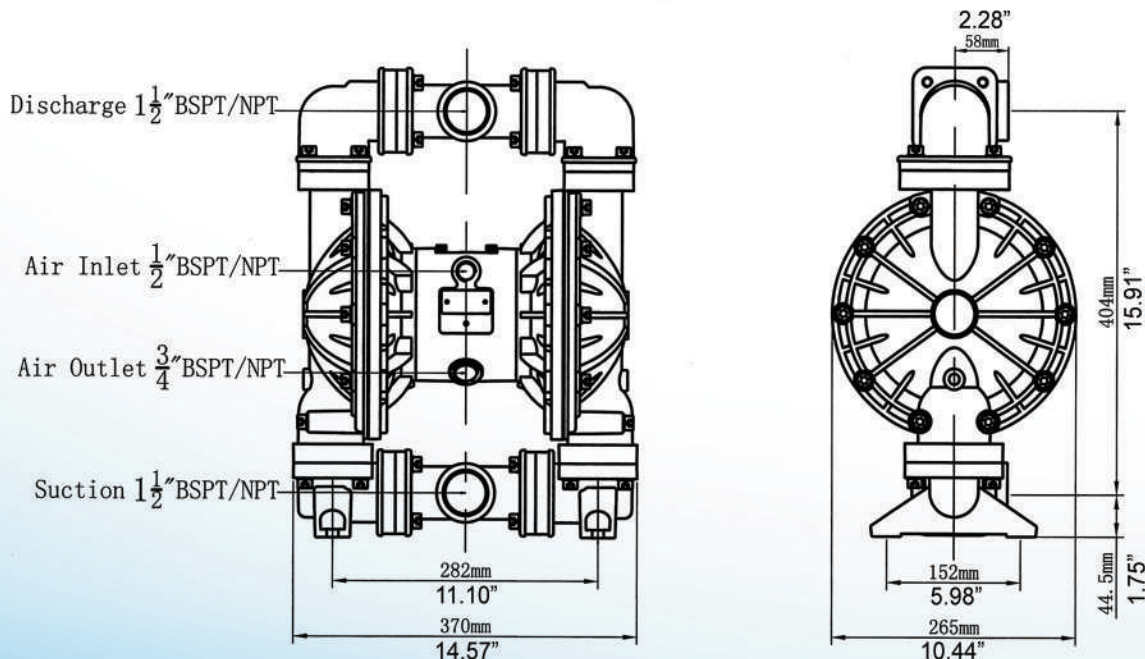



BD 40 Plastic Pump

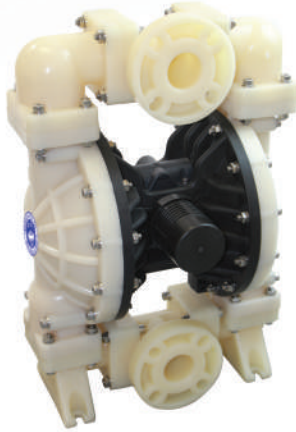

Performance Curve

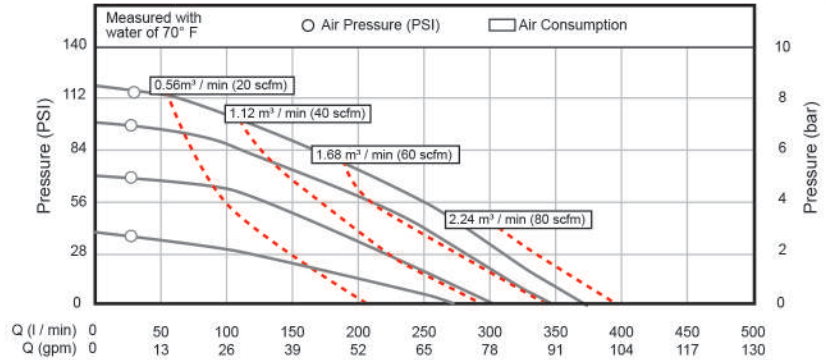

Technical Parameters	Material Specifications
Suction Lift (mwc) - Dry 5 - Wet 8	Diaphragm: Santoprene, Hytrel, Teflon, Viton, EPDM, Buna-N
Max particle diameter (mm) 5	Pump Body: PP, PVDF
Suction and Discharge 1-1/2"	Check Valve: TF, SS, ST, HY, VT, CM
Air inlet size 1/2"	Center Block: PP, AL, SS
Max flow 95 GPM	WEIGHT
Max Head - 275 Feet	PP pump / POM Pump 37 lbs.
Max air inlet pressure 122 PSI	PVDF Pump: 53 lbs.

Dimensions

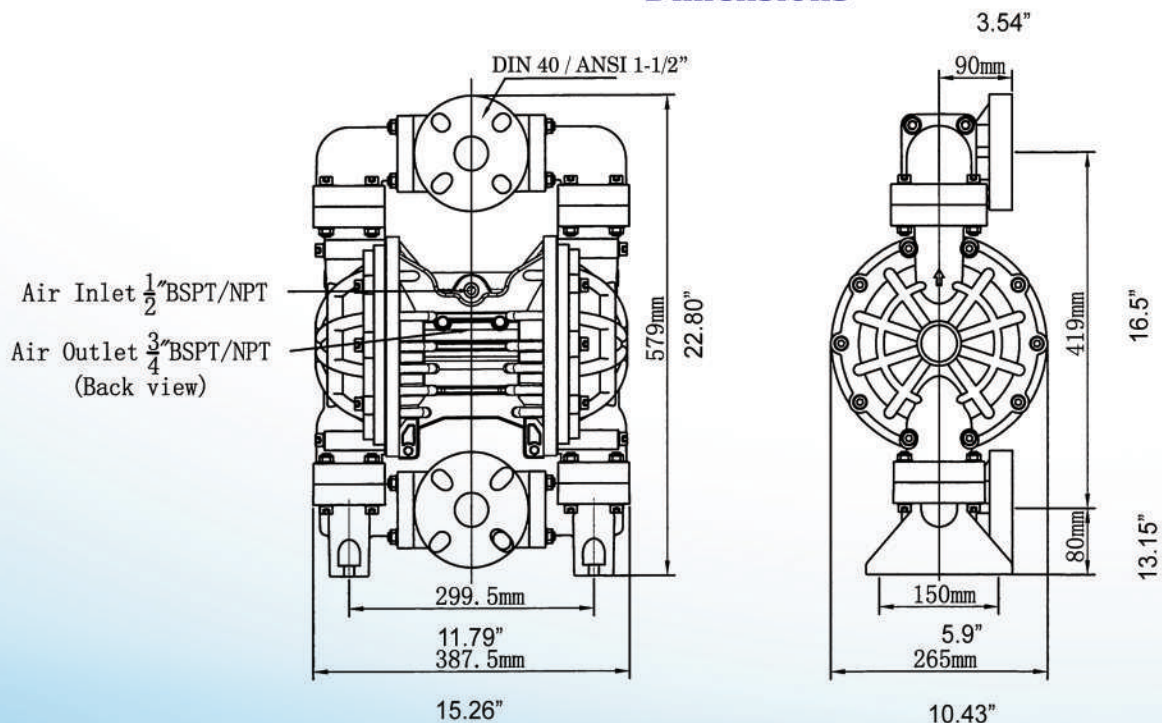



BD 40 Stainless Steel Pump



Performance Curve

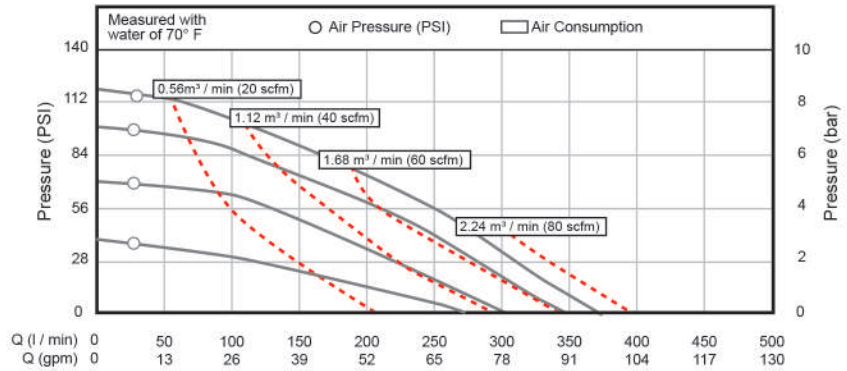

Technical Parameters	Material Specifications
Suction Lift (mwc) - Dry 5 - Wet 8	Diaphragm: Santoprene, Hytrel, Teflon, Viton, EPDM, Buna-N
Max particle diameter (mm) 5	Pump Body: SS304, SS316, SS316L
Suction and Discharge 1-1/2"	Check Valve: ST, HY, TF, VT, SS, CM
Air inlet size 1/2"	Center Block: PP, AL, SS
Max flow 95 GPM	WEIGHT
Max Head - 275 Feet	SS304 Pump 68 lbs.
Max air inlet pressure 122 PSI	SS316 Pump: 68 lbs.

Dimensions

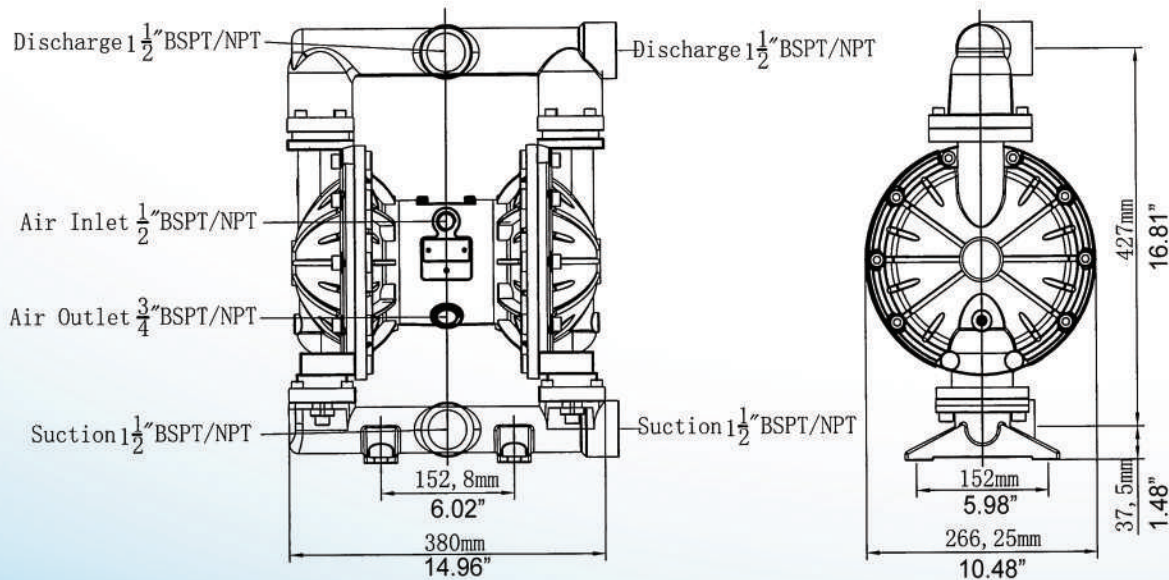



BD 50 Aluminum / Cast Iron Pump

Performance Curve

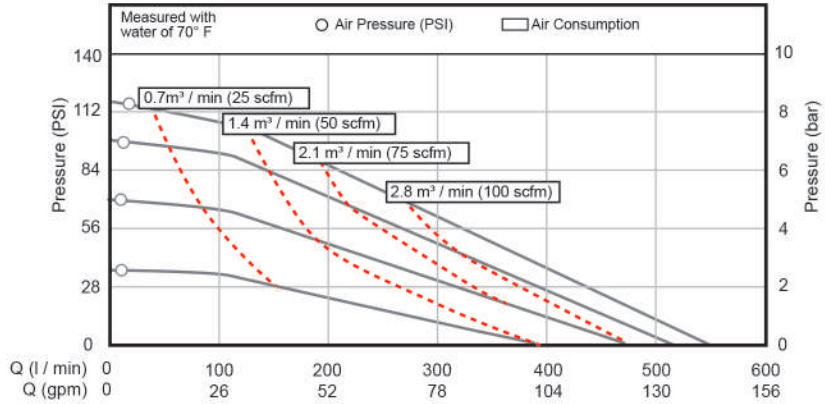

Technical Parameters	Material Specifications
Suction Lift (mwc) - Dry 5 - Wet 8	Diaphragm: Santoprene, Hytel, Teflon, Viton, EPDM, Buna-N
Max particle diameter (mm) 6	Pump Body: Aluminum, Cast Iron
Suction and Discharge 2"	Check Valve: ST, HY, TF, VT, SS, CM
Air inlet size 1/2"	Center Block: PP, AL, SS
Max flow 155 GPM	WEIGHT
Max Head - 275 Feet	Aluminum Pump 59 lbs.
Max air inlet pressure 122 PSI	Cast Iron Pump: 172 lbs.

Dimensions

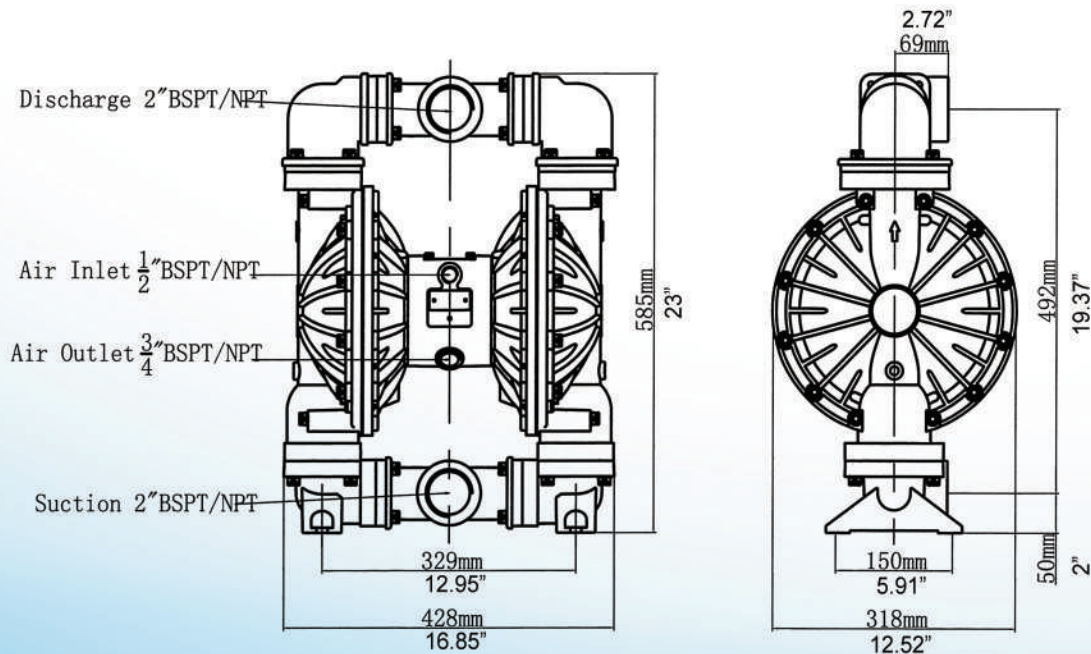



BD 50 Plastic Pump

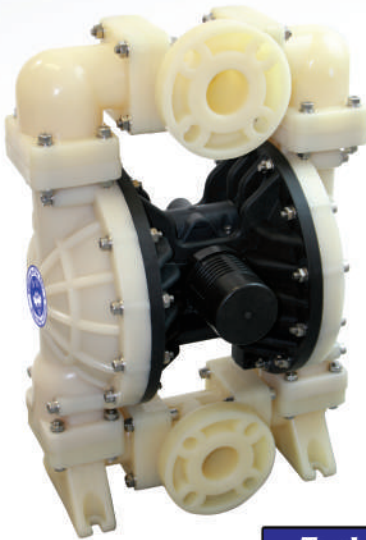

Performance Curve

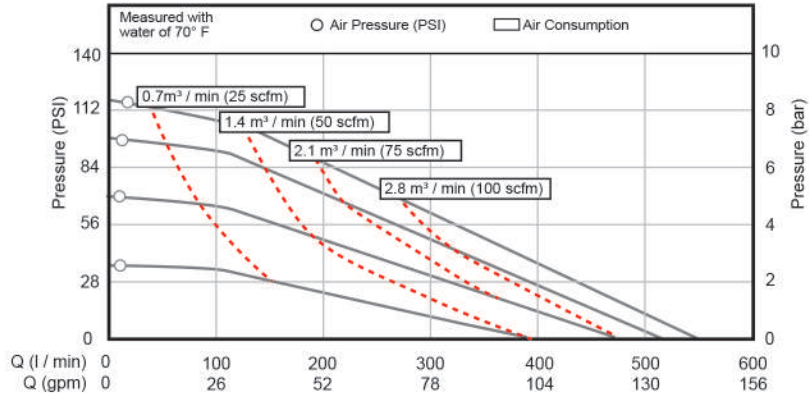

Technical Parameters	Material Specifications
Suction Lift (mwc) - Dry 5 - Wet 8	Diaphragm: Santoprene, Hytrel, Teflon, Viton, EPDM, Buna-N
Max particle diameter (mm) 6	Pump Body: PP, PVDF
Suction and Discharge 2"	Check Valve: TF, SS, ST, HY, VT, CM
Air inlet size 1/2"	Center Block: PP, AL, SS
Max flow 155 GPM	WEIGHT
Max Head - 275 Feet	PP Pump 155 lbs.
Max air inlet pressure 122 PSI	PVDF Pump: 175 lbs.

Dimensions

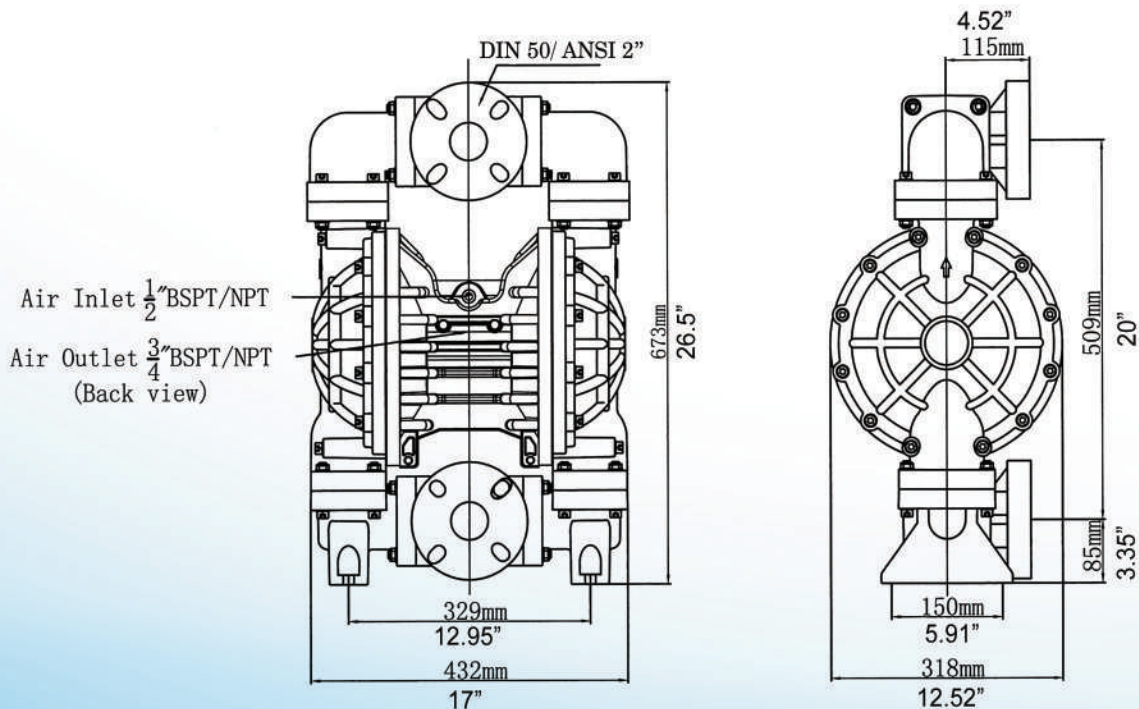



BD 50 Stainless Steel Pump



Performance Curve

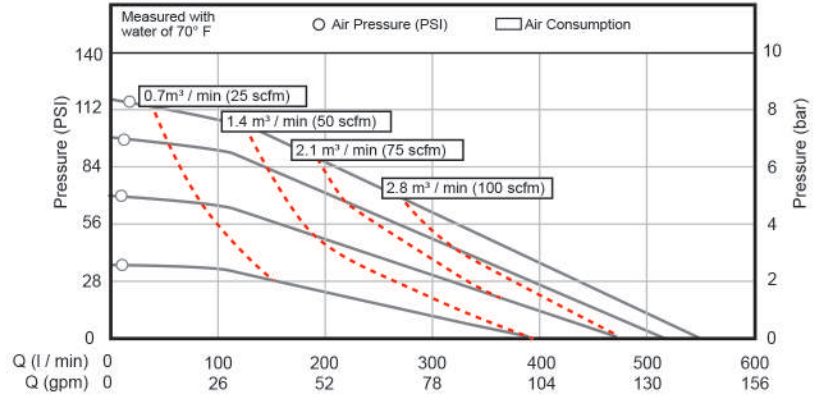

Technical Parameters	Material Specifications
Suction Lift (mwc) - Dry 5 - Wet 8	Diaphragm: Santoprene, Hytrel, Teflon, Viton, EPDM, Buna-N
Max particle diameter (mm) 6	Pump Body: SS304, S316, SS316L
Suction and Discharge 2"	Check Valve: ST, HY, TF, VT, SS, CM
Air inlet size 1/2"	Center Block: PP, AL, SS
Max flow 155 GPM	WEIGHT
Max Head - 275 Feet	SS304 Pump 106 lbs.
Max air inlet pressure 122 PSI	SS316 Pump: 106 lbs.

Dimensions

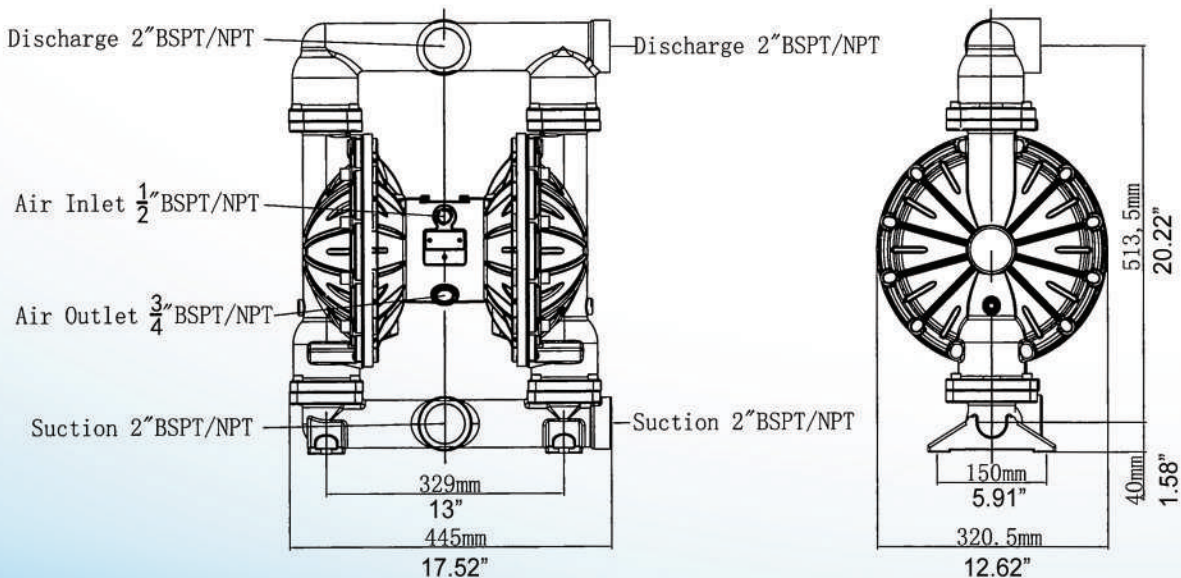



BD 80 Aluminum Pump



Performance Curve

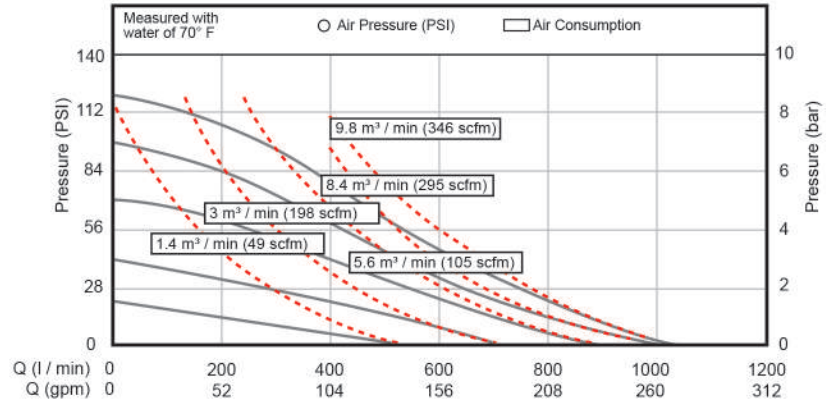

Technical Parameters	Material Specifications
Suction Lift (mwc) - Dry 5 - Wet 8	Diaphragm: Santoprene, Hytrel, Teflon, Viton, EPDM, Buna-N
Max particle diameter (mm) 9.4	Pump Body: Aluminum
Suction and Discharge 3"	Check Valve: ST, HY, TF, VT, SS, CM
Air inlet size 3/4"	Center Block: PP, AL, SS
Max flow 280 GPM	WEIGHT
Max Head - 275 Feet	Aluminum 110 lbs.
Max air inlet pressure 122 PSI	

Dimensions

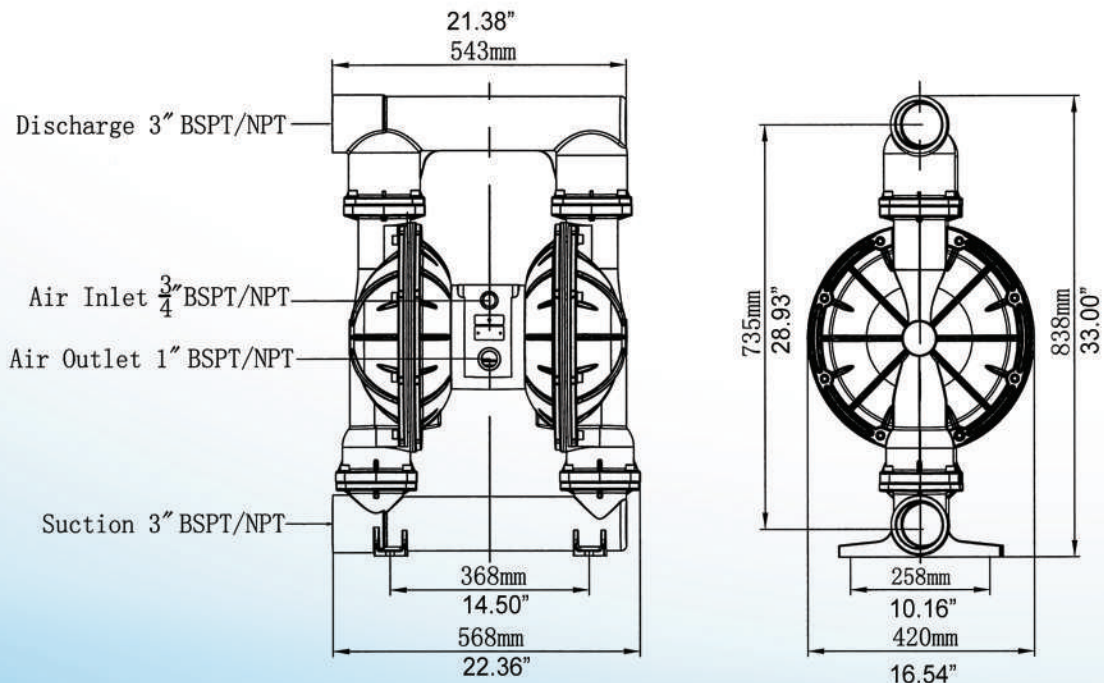



BD 80 Plastic Pump



Performance Curve

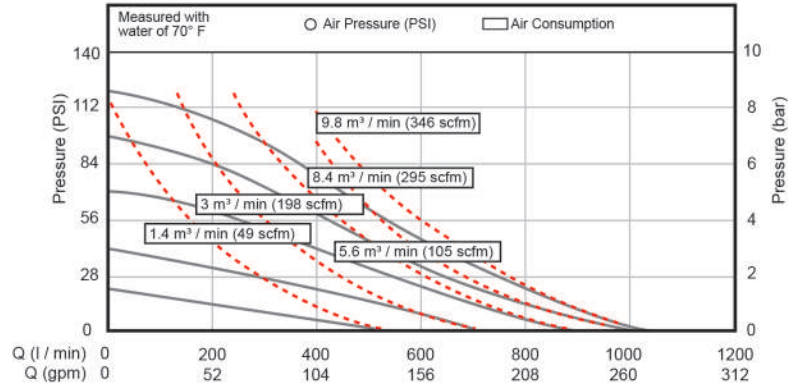

Technical Parameters	Material Specifications
Suction Lift (mwc) - Dry 5 - Wet 8	Diaphragm: Santoprene, Hytel, Teflon, Viton, EPDM, Buna-N
Max particle diameter (mm) 9.4	Pump Body: PP, PVDF
Suction and Discharge 3"	Check Valve: TF, SS, ST, HY, VT, CM
Air inlet size 3/4"	Center Block: PP, AL, SS
Max flow 280 GPM	WEIGHT
Max Head - 275 Feet	PP Pump 110 lbs.
Max air inlet pressure 122 PSI	PVDF Pump: 198 lbs.

Dimensions

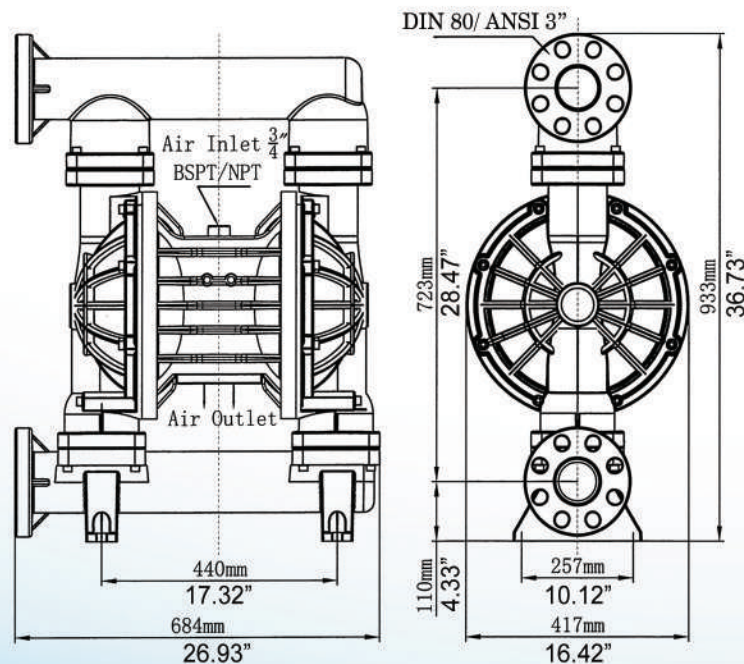



BD 80 Stainless Steel Pump



Performance Curve

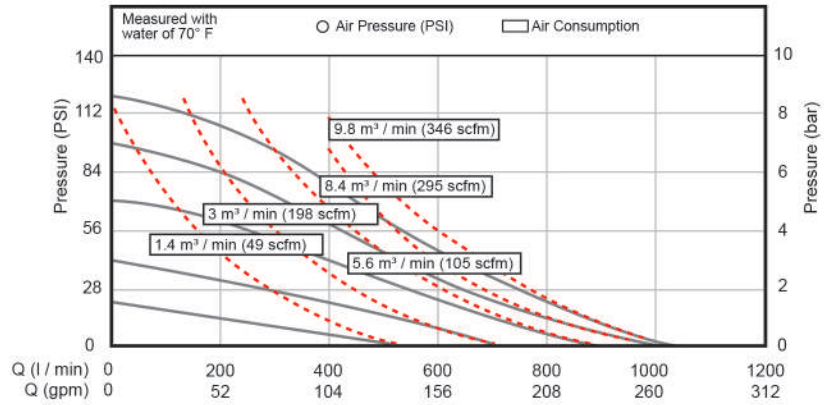

Technical Parameters	Material Specifications
Suction Lift (mwc) - Dry 5 - Wet 8	Diaphragm: Santoprene, Hytrel, Teflon, Viton, EPDM, Buna-N
Max particle diameter (mm) 9.4	Pump Body: PP, PVDF
Suction and Discharge 3"	Check Valve: TF, SS, ST, HY, VT, CM
Air inlet size 3/4"	Center Block: PP, AL, SS
Max flow 280 GPM	WEIGHT
Max Head - 275 Feet	SS304 Pump 270 lbs.
Max air inlet pressure 122 PSI	SS316 Pump: 270 lbs.

Dimensions

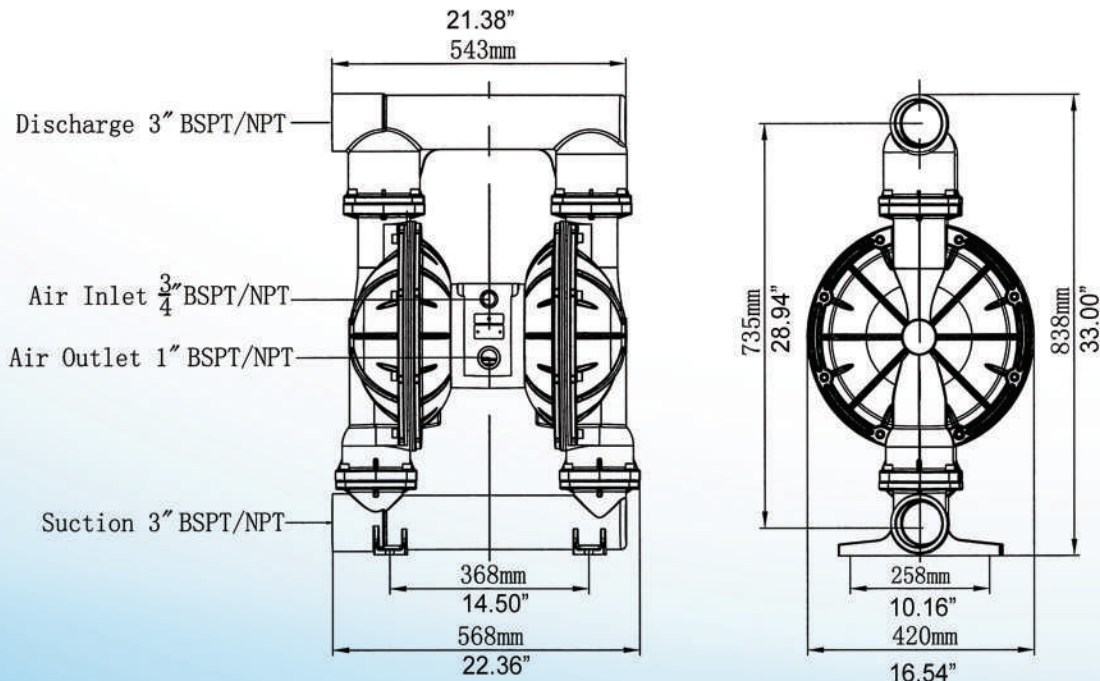



BD 50 Flap Valve Aluminum Pump

Pump model and material code

MODEL: **BD**

50

AL

AL

HY

F

PUMP SIZE:
50=2 inch

CENTER BLOCK:
AL=Aluminum
PP=Polypropylene

PUMP BODY:
AL=Aluminum
PP=Polypropylene

DIAPHRAGM:
TF=PTeflon
ST=Santoprene
HY=Hytrell
VT=Viton

PUMP TYPE
F=Flap valve

Pump Characteristics

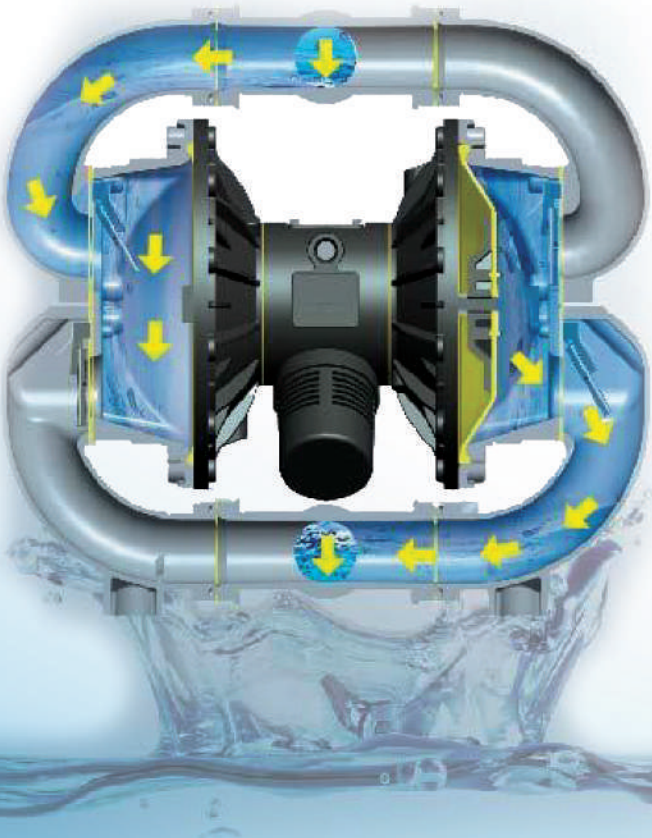

- Flap valve design, excellent particle pass ability
- Upper port inlet, bottom port outlet
- No dynamic seal, dry running without damage
- No impeller, low shear
- Manifold port direction can adjustment
- Excellent suction ability
- Light weight design, flexible installation



BD 50 Flap Valve Aluminum Pump



Weight:
Aluminum: 60 lbs.

Performance Curve

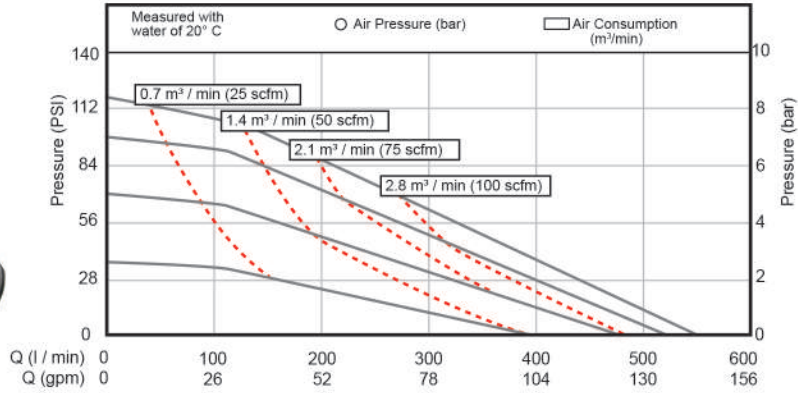

Technical Parameters

Suction Lift (mwc) - Dry	4
- Wet	7.6
Max particle diameter (mm)	45
Suction and Discharge	2"
Air inlet size	1/2"
Max flow	155 GPM
Max Head	275 Feet
Max air inlet pressure	122 PSI

Dimensions

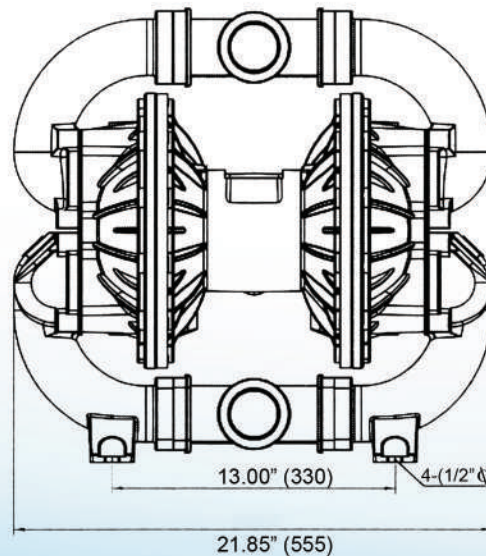
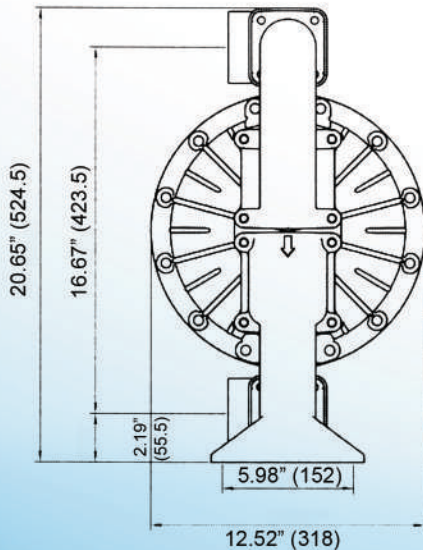



Pinnacle-Flo, Inc.

Filter Regulator

How to Operate the Filter Regulator

Set the regulator while verifying the displayed values of the inlet and outlet pressure gauges. To do this first pull up the pressure regulator knob to unlock it. You can visually verify if the cap is unlocked by seeing the orange mark that appears in the gap under the cap. Turn the knob clockwise to increase pressure to the piece of equipment that you are operating and counter clockwise to reduce the pressure. Once the desired pressure has been reached push the knob down to lock it in place.

When the polycarbonate bowl needs to be removed and then reinstalled make sure the lock button lines up to the groove of the front (or the back) of the body to avoid drop or damage of the bowl.

Replace the element every 2 years or when a 1 pound pressure drop is noticed. Do this to prevent damage to the element.



Part # BDW30-N03G-Z-B	3/8" NPT Port	For use with BD15 (1/2") and BD20 (3/4") Pumps
Part # BDW40-N04G-Z-B	1/2" NPT Port	For use with BD25 (1"), BD40 (1.5") and BD50 (2") Pumps
Part # BDW40-N06G-Z-B	3/4" NPT Port	For use with BD80 (3") Pump

Here at Pinnacle-Flo, Inc...

...We always have parts available.





Pinnacle-Flo, Inc.

IMPROVE EFFICIENCY AND PROTECT YOUR AODD SYSTEM

Pair the Blue Dog with a pulsation dampener designed specifically for AODD pumps:

AODDampener™

POWERED BY **BLACOH**
FLUID CONTROL



WHAT MAKES THIS UNIT NECESSARY?

Utilize this unit to extend the life of your AODD pump, reduce harmful vibrations, and save on overall system energy costs. The Blacoh AODDampener is specifically designed for AODD pumps and constructed of 316L Stainless Steel with a PTFE backed diaphragm. This single configuration will allow the unit to handle most AODD applications and is great for any of the Pinnacle-Flow pump materials.

We are dedicated to providing you with the most competitive pricing while still maintaining that the AODDampener is sourced, manufactured and assembled to ISO 9001:2015 standards here in the United States. Like all Blacoh products, you can be assured of the quality and care put into every unit.

www.Pinnacle-Flo.com

CONSTRUCTED OF
316L STAINLESS STEEL
HOUSING



ALL UNITS WITH
PTFE BACKED
DIAPHRAGM



FULLY
AUTOMATIC
AIR CONTROL



OFFERED IN
1, 1.5 & 2" NPT
CONNECTIONS





Pinnacle-Flo, Inc.



OFFERING FULL SYSTEM SOLUTIONS

Thank you for your purchase from Pinnacle-Flo, Inc. We also offer a wide range of system accessories by Blacoh to ensure that your system flow is running smoothly and is well protected. Get everything you need from one single source that you know and trust.



Pulsation Dampeners

Pulsation Dampeners & Surge Suppressors remove water hammer, hydraulic shock and up to 99% of vibration. Enhance performance and protect the lifetime of your whole system.



SpillStop Leak Containment

The fully pneumatic SpillStop™ system safely captures leaked product and automatically shuts down failed pumps to eliminate costly product loss and prevent hazardous spills.



Diaphragm Seals

Gauge guards or diaphragm seals isolate all forms of system instrumentation or gauges from hazardous and corrosive process fluids. Lifetime guaranteed with terms & conditions.



Injection Quills

Injection quills are used to provide safe delivery of chemicals into pipelines. The quill end ensures the dispersion of the chemicals away from the pipe wall.



Back Pressure Valves

Back pressure valves enhance the performance of pumping systems by applying a continuous back pressure to the system pump, while also acting as an anti-syphon valve.



Pressure Relief Valves

Pressure relief valves protect pumping systems from over pressure damage caused by defective equipment or a blockage in the pump system line.



Calibration Columns

Calibration columns & cylinders determine pump flow rate for metering pumps quickly and easily. They enhance the performance of your chemical feed systems and are easy to read.



Hybrid Valve

The new patent-pending Hybrid Valve™ combines the steady flow control of a pulsation dampener and the regulation of a back pressure valve to deliver the performance of both in one easy to use unit.



Pinnacle-Flo, Inc.



Self Priming Solids Handling Pump
Mad Dog series

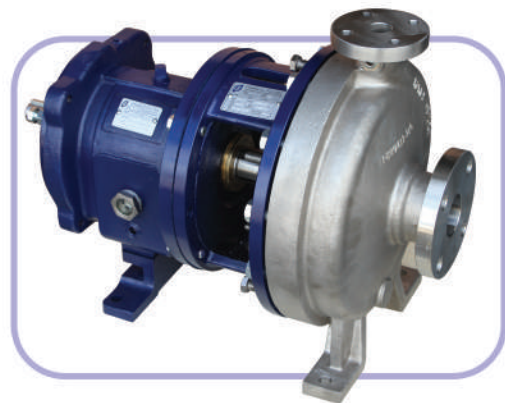

Pinnacle 8896
ANSI pump series

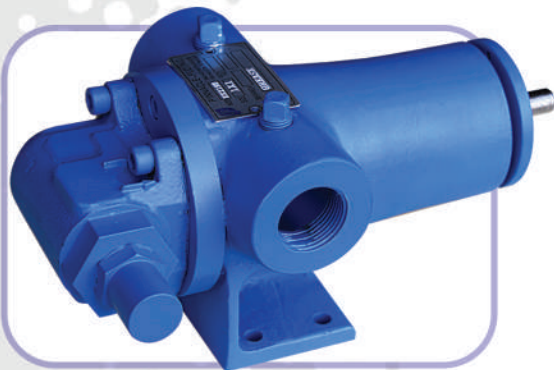

Gear Pump
Buffalo series

Pinnacle-Flo, Inc.

10620 Stebbins Circle Suite D • Houston, TX 77043

Office: (832) 303-1245 / Fax: (832) 900-9398

www.pinnacle-flo.com

email: sales@pinnacle-flo.com